

FCC STATEMENT

This device complies with Part 15 of the FCC Rules. Operation is subject to the following two conditions:

- (1) This device may not cause harmful interference, and
- (2) This device must accept any interference received, including interference that may cause undesired operation.

Note:

This equipment has been tested and found to comply with the limits for Class B digital devices, pursuant to Part 15 of the FCC rules. These limits are designed to provide reasonable protection against harmful interference in a residential installation. This equipment generates, uses and can radiate radio frequency energy and, if not installed and used in accordance with the instructions, may cause harmful interference to radio communications.

However, there is no guarantee that interference will not occur in a particular installation. If this equipment does cause harmful interference to radio or television reception, which can be determined by turning the equipment off and on, the user is encouraged to try to correct the interference by one or more of the following measures:

- Reorient or relocate the receiving antenna
- Increase the separation between the equipment and receiver
- Connect the equipment into an outlet on a circuit different from that to which the receiver is connected
- Consult the dealer or an experienced radio/TV technician for help

Use of shielded cable is required to comply with Class B limits in Subpart B of Part 15 of the FCC rules. Do not make any changes or modifications to the equipment unless otherwise specified in the manual. If such changes or modifications should be made, you could be required to stop operation of the equipment.

TRADEMARK INFORMATION

- Microsoft® and Windows® are U.S. registered trademarks of Microsoft Corporation.
- Pentium® is a registered trademark of Intel Corporation.
- Macintosh is a trademark of Apple Computer, Inc.
- SD™ is a trademark.
- Other names and products may be trademarks or registered trademarks of their respective owners.

READ THIS FIRST

Notice:

1. Product design and specifications are subject to change without notice. This includes primary product specifications, software, software drivers, and user's manual. This User Manual is a general reference guide for the product.
2. The product and accessories that come with your camera may be different from those described in this manual. This is due to the fact that different retailers often specify slightly different product inclusions and accessories to suit their market requirements, customer demographics, and geographical preferences. Products very often vary between retailers especially with accessories such as batteries, chargers, AC adapters, memory cards, cables, pouches, and language support. Occasionally a retailer will specify a unique product color, appearance, and internal memory capacity. Contact your dealer for precise product definition and included accessories.
3. The illustrations in this manual are for the purpose of explanation and may differ from the actual design of your camera.
4. The manufacturer assumes no liability for any errors or discrepancies in this user manual.

Safety Instructions

Read and understand all **Warnings** and **Cautions** before using this product.

WARNING

If foreign objects or water have entered the camera, turn the power OFF and remove the battery and the AC power adapter.

Continued use in this state might cause fire or electric shock. Consult the store of purchase.



If the camera has fallen or its case has been damaged, turn the power OFF and remove the battery and the AC power adapter.

Continued use in this state might cause fire or electric shock. Consult the store of purchase.



Do not disassemble, change or repair the camera.

This might cause fire or electric shock. For repair or internal inspection, ask the store of purchase.



Use the specified AC power adapter only with the indicated power supply voltage.

Use with any other power supply voltage might cause fire or electric shock.



Do not use the camera in areas near water.

This might cause fire or electric shock. Take special care during rain, snow, on the beach, or near the shore.



Do not place the camera on inclined or unstable surfaces.

This might cause the camera to fall or tilt over, causing injury.



Keep the battery out of the reach of children.

Swallowing battery might cause poisoning. If the battery is accidentally swallowed, immediately consult a physician.



Do not use the camera while you are walking, driving or riding a vehicle.

This might cause you to fall over or result in traffic accident.



CAUTION

Insert the battery paying careful attention to the polarity (+ or -) of the terminals.

Inserting the battery with its polarities inverted might cause fire and injury, or damage to the surrounding areas due to the battery rupturing or leaking.



Do not fire the flash close to anyone's eyes.

This might cause damage to the person's eyesight.



Do not subject the LCD monitor to impact.

This might damage the glass on the screen or cause the internal fluid to leak. If the internal fluid enters your eyes or comes into contact with your body or clothes, rinse with fresh water. If the internal fluid has entered your eyes, consult a physician to receive treatment.



A camera is a precision instrument. Do not drop it, strike it or use excessive force when handling the camera.

This might cause damage to the camera.



Do not use the camera in humid, steamy, smoky, or dusty places.

This might cause fire or electric shock.



Do not remove the battery immediately after long period of continuous use.

The battery becomes hot during use. Touching a hot battery might cause burns.



Do not wrap the camera or place it in cloth or blankets.

This might cause heat to build up and deform the case, resulting in fire. Use the camera in a well-ventilated place.



Do not leave the camera in places where the temperature may rise significantly, such as inside a car.

This might adversely affect the case or the parts inside, resulting in fire.



Before you move the camera, disconnect cords and cables.

Failure to do this might damage cords and cables, resulting in fire and electric shock.



Notes on Battery Usage

When you use the battery, carefully read and strictly observe the **Safety Instructions** and the notes described below:

- Use only the specified battery (3.7V).
- Avoid using the battery in extremely cold environments as low temperatures can shorten the battery life and reduce camera performance.
- When you are using the new rechargeable battery or rechargeable battery that has not been used for an extended period of time (the battery that passed the expiry date is an exception) might affect the number of images that can be captured. Therefore, to maximize its performance and lifetime, we recommend that you fully charge the battery and discharge it for at least one complete cycle before use.
- The battery may feel warm after long period of continuous use of the camera or the flash. This is normal and not a malfunction.
- The camera may feel warm after long period of continuous use. This is normal and not a malfunction.
- If the battery is not to be used for a long period of time, remove it from the camera to prevent leakage or corrosion.
- If the battery is not to be used for a long period of time, store it after no battery power left. If the battery is stored for a long time in a fully charged state, its performance may be impaired.
- Always keep the battery terminals clean.
- Batteries can explode if replaced by an incorrect type.
- Dispose of used batteries according to the recycle instructions.
- We recommend the battery should be charged for 8 hours at its first use.

CONTENT

8 INTRODUCTION

- 8 Overview
- 10 Package Contents

11 GETTING TO KNOW THE CAMERA





- 11 Front View
- 12 Rear View
- 15 Status LED Indicator
- 16 LCD Monitor Icons

20 GETTING STARTED

- 20 Attaching the Camera Strap
- 20 Inserting and Removing the Battery
- 21 Charging the Battery
- 22 Using an AC Power Adapter
- 22 Inserting and Removing an SD Memory Card (Optional Accessory)
- 23 Turning the Power On/Off
- 24 Setting the Date and Time
- 25 Choosing the Display Language
- 26 Formatting an SD Memory Card or Internal Memory
- 27 Setting Image Resolution and Quality

30 PHOTOGRAPHY MODE

- 30 [**A**] Auto Mode
- 31 Recording Voice Memos
- 32 Using the Optical Zoom

- 33 Using the Digital Zoom
- 34 Setting the Flash
- 36 Setting the Focus
- 37 Setting the Self-timer
- 38 Exposure Compensation/Backlight Correction
- 39 [**SCN**] Scene Mode
- 41 [**P**] Program (Automatic Exposure) Photography Mode
- 42 [**Tv**] Shutter Speed Priority Photography Mode
- 43 [**Av**] Aperture Priority Mode
- 44 [**M**] Manual Mode
- 45 [] User Setting Mode
- 45 [] Video Mode
- 46 [] Panorama Mode
- 46 [] Anti-Shake Mode
- 47 Recording a Subject onto an Existing Background Image (Pre-Shot)
- 49 Combining Shots of Two People into a Single Image (Coupling Shot)

50 [] PLAYBACK MODE

- 50 Playing Back Still Images
- 51 Playing Back Video Clips
- 52 Playing Back Still Images/Video Clips on a TV
- 53 Attaching Voice Memos
- 54 Thumbnail Display
- 55 Zoom Playback

- 56 Slideshow Display
- 57 Protecting Images
- 59 DPOF Settings
- 61 Copying Files from Internal Memory to a Memory Card
- 62 Changing the Camera Start Logo Image
- 63 [] Deleting Images

66 MENU OPTIONS

- 66 Photography Menu (Capture tab)
- 69 Photography Menu (Function tab)
- 71 Photography Menu (AE/AWB tab)
- 73 Playback Menu
- 74 Setup1 Menu
- 75 Setup2 Menu

76 TRANSFERRING RECORDED IMAGES AND VIDEOS TO YOUR COMPUTER

- 77 Connecting the Camera to Your Computer
- 78 Downloading Images and Video Files

79 CONNECTING TO A PICTBRIDGE COMPLIANT PRINTER

81 EDITING SOFTWARE INSTALLATION

- 81 Installing Photo Explorer
- 82 Installing Photo Express
- 83 Installing Cool 360

84 CAMERA SPECIFICATIONS

85 TROUBLESHOOTING

INTRODUCTION

Overview

Congratulations on your purchase of the new digital camera.

Capturing high-quality digital images is fast and easy with this state-of-the-art smart camera. Equipped with a 10.1-megapixel CCD, this camera is capable of capturing images with a resolution of up to 3648 x 2736 pixels.

Other cool features provided by the camera include the following:

- LCD monitor -** 2.5" full color LTPS-TFT LCD (230K pixels) monitor makes it easy to frame your subject when capturing images. It also displays the images you have captured.
- Recording media -** 32 MB internal memory (26 MB available for image storage). External memory supports SD memory cards up to 2 GB.
- Optical zoom -** The 3x optical lens allows you to capture telephoto and wide-angle images.
- Digital zoom -** 10.4x digital zoom in conjunction with the 3x optical zoom permit zoom photography of up to 31.2x. Captured images may be reviewed and a selected portion of an image may be enlarged up to 8x.
- Flexible flash settings -** You may adjust the flash setting according to your lighting environment.
- Focus mode -** Images can be captured with the distance to the subject set by normal auto focus, macro or infinity.
- Self-timer mode -** The self-timer may set to 10 seconds, 2 seconds or 10+2 seconds.
- Video mode -** In addition to still-images, you may capture video clips with audio (voice).
- Voice memo -** You may annotate your images with a 30 second voice memo. Images may be voice-annotated at the time of capture, or during playback.
- Thumbnail display -** Display your images in sets of nine on the LCD monitor for quick selection of an particular image.

- TV and PC connection -** You may view your images on a television monitor or a computer using the USB or A/V cables.
- DPOF support -** You may print your images on a DPOF compatible printer by simply inserting the memory card with embedded printing information.
- Photography mode -** The camera has 10 different photography modes such as Auto, Scene, Program, Shutter Speed Priority, Aperture Priority, Manual, User Setting, Video, Panorama and Anti-Shake. By setting the mode dial, the camera controls the exposure focus and white balance depending on the selected mode.
- Scene mode -** Simply select the scene mode that suits specific shooting conditions and subjects. This lets you shoot for the results you desire without complicated settings.

Package Contents

Carefully unpack your kit box and ensure that you have the following items:

- Digital Camera
- A/V cable
- USB cable
- User's manual
- Software CD-ROM
- Camera strap
- Camera pouch
- AC power adapter
- Rechargeable lithium-ion battery

Optional Accessories:

- SD memory card
- Battery charger



NOTE

- Accessories may vary by retailer.

GETTING TO KNOW THE CAMERA



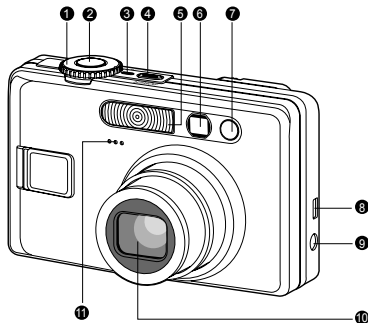

Front View

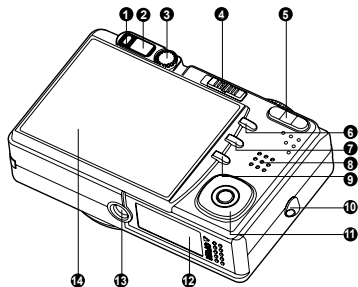

#	Name	Description
1	Mode dial	Sets the camera mode.
2	Shutter button	Focuses and locks both focus & exposure when pressed halfway down. Captures the image when pressed all the way down.
3	Power indicator	Lights on when the camera power is turned on.
4	POWER (Power) button	Turns the camera power on and off.
5	Flash	Provides flash illumination.
6	Viewfinder window	Allows you to frame the subject of the image.
7	Self-timer LED (AF auxiliary light)	Blinks during Self-timer mode until the image is captured. Lights for auto focusing when capturing in a dark place.
8	USB or A/V OUT terminal	Allows you to connect a USB cable or an A/V cable to the camera.
9	DC IN 5V terminal	Allows you to connect an AC power adapter to operate the camera without battery, or to charge rechargeable lithium-ion battery.
10	Lens	3x optical zoom lens allows you to capture telephoto and wide-angle images.
11	Microphone	For recording audio with video clips and voice annotation.

Rear View



#	Name	Description
1	Status LED	Displays the camera current state.
2	Viewfinder window	Allows you to compose your subject using the optical viewfinder.
3	Diopter adjustment dial	Provides a clearer image when using the optical viewfinder.
4	Mode switch  Photography mode  Playback mode	Sets the camera mode. Selects this when capturing still images or recording video clips. Performs image playback and deletion.
5	↑ (Zoom in) button  (Zoom out) button	Zooms the lens to telephoto position. Zooms the lens to wide-angle position.
6	MENU (Menu) button	Toggles On-Screen Display (OSD) menu on and off.
7	 (Delete) button	Allows you to delete an image.
8	Speaker	Produces camera sounds and plays recorded audio.
9	 (Display) button	Changes the information displayed on the LCD monitor.
10	Strap holder	Camera strap attachment.
11	SET /Direction button	Allows you to scroll through menus and images, and then select your choices.
12	Battery/SD card cover	Access to the battery and memory card.
13	Tripod socket	For tripod mounting.
14	LCD monitor	For image preview/review. Displays control menus, camera settings, and operational icons.



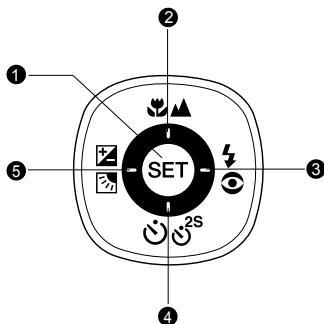

SET /Direction button

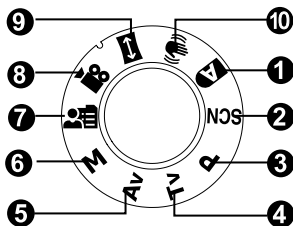

#	Name	Description
1	SET button	Enters the menu page and confirms the chosen setting.
2	▲ button 📍▲ (Focus) button	Scrolls upwards. Allows you to choose the appropriate focus setting.
3	▶ button ⚡ (Flash) button	Scrolls right. Allows you to choose the appropriate flash setting.
4	▼ button 🕒 (Self-timer) button	Scrolls downwards. Allows you to toggle the self-timer on and off, selects the desired self-timer mode.
5	◀ button ☒ (Exposure compensation/ Backlight correction) button	Scrolls left. Allows you to toggle the exposure compensation/backlight correction on and off.

Mode dial



#	Name	Description
1.	A Auto	The camera automatically sets for exposure, etc.
2.	SCN Scene Mode	Point-and-shoot simplicity when capturing images under 16 special conditions.
3.	P Program (auto exposure)	In program mode the shutter speed and aperture will be set automatically, but other parameters may be set manually.
4.	Tv Shutter Speed Priority	You may specify the shutter speed while the camera sets the corresponding aperture value.
5.	Av Aperture Priority	You may specify the aperture value while the camera sets the corresponding shutter speed.
6.	M Manual	For full manual control over exposure, aperture and other settings.
7.	 User Setting	This mode allows you manually set the setting parameters and all these settings will be memorized.
8.	 Video	For recording video clips.
9.	 Panorama	Allows you to capture panorama (stitch-assist) shots.
10.	 Anti-Shake	DSP anti-shake could minimize (not 100% reduce) the jitter from shaky hands that causes many images to look blurred by shifting the lens unit. This mode offsets unintentional hand movement while you are capturing images to give you clear, sharp images even when taking handheld telephoto shots or shooting at night.





















Status LED Indicator

The status LED indicates the current operational status of the camera. The meaning of the LED changes depending upon what the camera is doing.

Color	State	During power off	During photography	During connection to a PC
Green	On	The completion of battery charge.	AE or AF is locked with the shutter button held halfway.	In communication to PC.
	Flashing	The battery is charging.	-	-
Red	On	An AC power adapter is connected, but a battery is not in a camera. Battery charging error.	Accessing files in progress.	-
	Flashing	-	When the image is not in focus.	-
Orange	On	-	Flash charging in progress.	-
	Flashing	-	Hardware malfunction.	-

LCD Monitor Icons

For Photography modes: [**A**], [**SCN**]

1. Mode icon
2. Storage media
[] Internal memory (no card)
[] SD memory card
3. Zoom status
4. Voice memo
5. Battery condition
[] Full battery power
[] Medium battery power
[] Low battery power
[] No battery power
6. Flash mode
[**Blank**] Auto Flash
[] Red-eye Reduction
[] Forced Flash
[] Flash Off
7. Main focus area
8. Capture mode icon
[**Blank**] Single
[] Continuous
[**AEB**] Auto Exposure Bracketing
[] Burst
9. Image size resolution
[] 3648 x 2736
[] 2816 x 2112
[] 2048 x 1536
[] 640 x 480
10. Available number of shots
11. Image quality
[*******] Fine
[******] Standard
[*****] Economy
12. Self-timer icon
[] 10 sec.
[] 2 sec.
[] 10+2 sec.
13. Date and time
14. Slow shutter warning
* Poor lighting conditions.
Images will be vulnerable to vibration.
15. Backlight correction
16. Focus setting
[**Blank**] Normal Auto Focus
[] Macro
[] Infinity



NOTE

- Pressing the [] button changes the LCD display in the sequence of: display with icons, help line, display without icons.
- To prevent a blur image we recommend that you use a tripod for capturing images when slow shutter warning icon appears.

For Photography modes: [P], [Tv], [Av], [M], [A-S], [A-M]

1. Mode icon
2. Storage media
3. Zoom status
4. Voice memo
5. Battery condition
6. Flash mode
7. Histogram
8. Main focus area
9. Capture mode icon
10. Image resolution
11. Available number of shots
12. Image quality
13. Self-timer icon
14. Shutter speed / Aperture
 - * In [P], [A-S] and [A-M] modes, Shutter speed / Aperture icon appears at half shutter (S1) condition.
15. Slow shutter warning
16. [A-S] Exposure compensation
- [A-M] Backlight correction
17. Metering
 - [A-S] Multi
 - [A-M] Spot
 - [A-S] Average

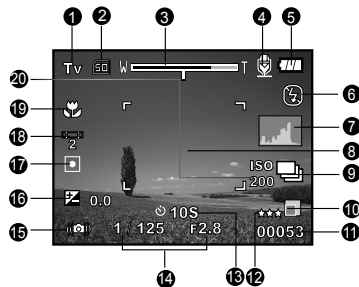

18. White balance
 - [Blank] Auto
 - [A-S] Incandescent
 - [A-M] Fluorescent 1
 - [A-S] Fluorescent 2
 - [A-M] Day Light
 - [A-S] Cloudy
 - [A-M] Manual
19. Focus setting
20. ISO



NOTE

- Pressing the [A-S] button changes the LCD display in the sequence of: display with icons, display with icons and histogram, helpline, display without icons.

For Photography mode: []

1. Mode icon
2. Storage media
3. Zoom status
4. Battery condition
5. Flash mode
6. White balance
7. Metering
8. Main focus area
9. [] Exposure compensation
[] Backlight correction
10. Image resolution
11. Available number of shots
12. Image quality
13. Image to be captured indicator
14. Focus setting
15. Slow shutter warning
16. ISO

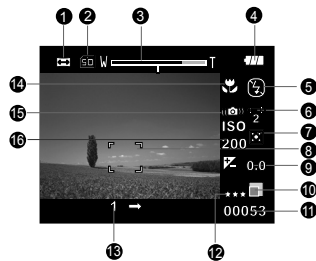

NOTE

- Pressing the [] button changes the LCD display in the sequence of: display with icons, display without icons.

For Video mode [📹]

1. Mode icon
2. Storage media
3. Zoom status
4. Battery condition
5. Video resolution
6. Available recording time/Elapsed time
7. Video quality
8. Self-timer icon
9. Date and time
- 10.White balance icon
- 11.Focus setting

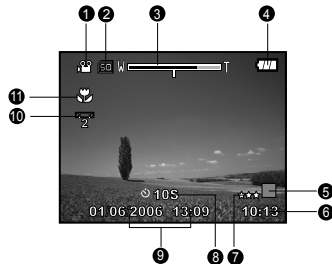

Playback mode [▶] -Still image playback

1. Mode icon
2. File number
3. Folder number
4. Protect icon
5. Voice memo
6. DPOF icon
7. Storage media



Playback mode [▶]-Video playback

1. Video status bar
2. Elapsed time
3. File number
4. Folder number
5. Protect icon
6. Mode icon
7. Play mode
8. Sound off icon (When the ▲ button is pressed during video playback)
9. Image quality
- 10.Image resolution
- 11.Frame rate
- 12.Storage media
- 13.Total recorded time

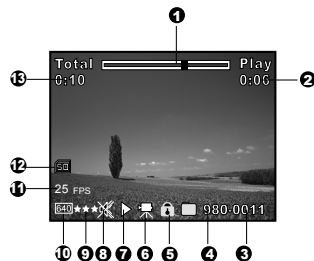

GETTING STARTED

Attaching the Camera Strap

Attach the camera strap as shown in the illustration.

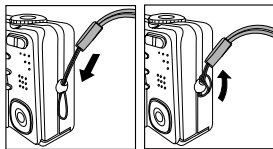

Inserting and Removing the Battery

We highly recommend using specified rechargeable lithium-ion battery (3.7V) to realize the full capability of your camera. Charge the battery fully before using the camera. Make sure that the power of the camera is off before inserting or removing the battery.

Inserting the Battery

1. Open the battery / SD memory card cover in the direction of the [OPEN] arrow.
2. Insert the battery in the correct orientation shown.
 - Tilt the battery lock lever, and then insert the battery in the direction of the arrow.
3. Close the battery / SD memory card cover.

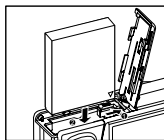
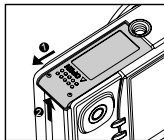

Removing the Battery

Open the battery / SD memory card cover and then release the battery lock lever. When the battery has come out a little, slowly pull it out the rest of the way.

Charging the Battery

Using the AC power adapter may charge the battery or operate the camera as power supply. Make sure that the power of the camera is off and then insert the battery before starting.

1. Insert one end of the AC power adapter into the DC IN 5V terminal of the camera.
2. Insert the other end of the AC power adapter into a wall outlet.
 - The status LED flashes green when charging is started and lights green when charging is completed. The LED lights red when a charging error has occurred.
 - It is recommended to fully discharge the battery before recharging.
 - Charging time varies according to the ambient temperature and the status of battery.

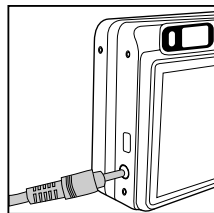

NOTE

- This camera must be used with specified AC power adapter. Damage caused by the use of an incorrect adapter is not covered under the warranty.
- Always make sure that the camera is off before removing the battery.
- The battery may feel warm after it has been charged or immediately after being used. This is normal and not a malfunction.
- When using the camera in cold conditions, keep the camera and battery warm by storing it in a warm place such as an interior pocket between shots.
- If you open the battery cover without removing the battery, the battery power will not be disconnected.
- If you remove the battery, you have to insert the battery within 2 hours in order to make sure that the date and time will not be reset.

Using an AC Power Adapter

Using an AC power adapter prevents the camera from automatically powered off while transferring files to your computer.

Perform the steps in the preceding section “Charging the Battery”.



NOTE

- Make sure to use only the AC power adapter specified for the digital camera. Damage caused by the use of an incorrect adapter is not covered under the warranty.

Inserting and Removing an SD Memory Card (Optional Accessory)

The digital camera comes with approx. 32 MB of internal memory (26 MB available for image storage), allowing you to store captured still images or video clips in the digital camera. However, you can also expand the memory capacity by using an SD memory card so that you can store more files.

Inserting an SD memory card

1. Open the battery / SD memory card cover.
2. Insert the SD memory card in the correct orientation shown.
 - Hold the SD memory card with its front side (printed arrow) facing the rear side of the camera, and then insert the card as far as it can go.
3. Close the battery / SD memory card cover.

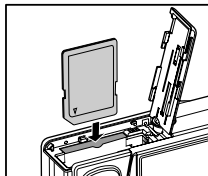

Removing an SD memory card

Open the battery / SD memory card cover, press lightly on the edge of the SD memory card and it will eject.



NOTE

- To prevent valuable data from being accidentally erased from an SD memory card you can slide the write-protected tab (on the side of the SD memory card) to “LOCK”.
- However, to save, edit or erase data on an SD memory card, you must unlock the card.
- Be sure to format an SD memory card with this digital camera before using it. Refer to section in this manual titled “Formatting an SD Memory Card or Internal Memory” for further details.
- To prevent the damage of an SD memory card, please turn off the power when inserting or removing the SD memory card. If inserting or removing the SD memory card with power on, the camera turns off automatically.

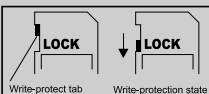

Turning the Power On/Off

1. Load the battery or connect the AC power adapter to your camera.
2. Press the **POWER** button to turn on your camera.
 - The status LED lights green and the camera is initiated.
 - The power indicator lights on when the camera power is turned on.
 - When the power is turned on, the camera will start in the mode that is currently selected.
3. To turn off your camera, press the **POWER** button again.

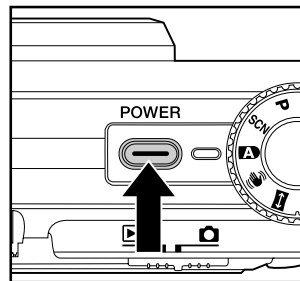

NOTE

- The power is turned off automatically when the camera has not been operated for a defined period of time. To resume the operation condition, turn the power on again. Refer to section in this manual titled "Auto OFF" in the Setup1 Menu for further details.
- When the power is turned on, it may take several seconds to charge the flash. While the flash is being charged, the status LED lights orange.
- The camera is not ready until the flash has charged. The camera is ready when the status LED is off.

Setting the Date and Time

The date/time needs to be set if/when:

- Camera is turned on for the first time.
- Camera is turned on after leaving the camera without the battery for an extended period of time.

When the date and time information is not displayed on the LCD monitor, follow these steps to set the correct date and time.

1. Slide the mode switch to [▶], and press the **MENU** button.
2. Select [Setup2] with the ▶ button.
3. Select [Date/Time] with the ▲ / ▼ buttons, and press the **SET** button.
 - The Date/Time setting screen will be displayed.
4. Select the item's field with the ◀ / ▶ buttons and adjust the value for the date and time with the ▲ / ▼ buttons.
 - The date and time is set in the order year-month-day-hour-minute.
 - The time is displayed in 24-hour format.
5. After confirming all settings are correct, press the **SET** button.
 - The setting will be stored and the screen will return to the [Setup2] menu.
6. To exit from the [Setup2] menu, press the **MENU** button.

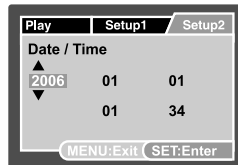
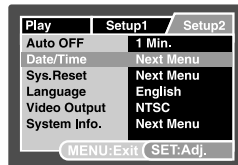
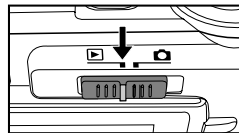

Choosing the Display Language

Choose an On-Screen Display (OSD) language for information to be displayed on the LCD monitor.

1. Slide the mode switch to [▶], and press the **MENU** button.
2. Select [Setup2] with the ▶ button.
3. Select [Language] with the ▲ / ▼ buttons, and press the **SET** button.
 - The language setting screen will be displayed.
4. Select the displayed language with the ▲ / ▼ buttons and press the **SET** button.
 - The setting will be stored.
5. To exit from the [Setup2] menu, press the **MENU** button.

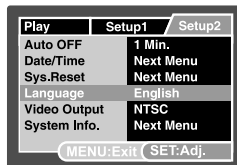

Formatting an SD Memory Card or Internal Memory

This function formats the internal memory (or memory card) and deletes all stored still images / video clips and data.

1. Slide the mode switch to [▶], and press the **MENU** button.
2. Select [Setup1] with the ▶ button.
3. Select [Format] with the ▲ / ▼ buttons, and press the **SET** button.
4. Select [Execute] with the ▲ / ▼ buttons, and press the **SET** button.
 - To cancel formatting, select [Cancel].
5. To exit from the [Setup1] menu, press the **MENU** button.

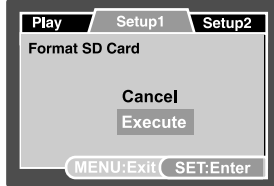
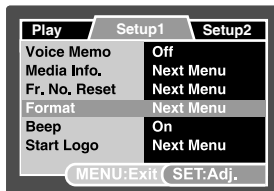

NOTE

- To format the internal memory, do not insert an SD memory card into the camera. Otherwise, you will format the SD memory card.
- Formatting the SD memory card also erases the protected images. All data other than images are also erased. Before formatting the card, make sure that all the images are unnecessary.
- Formatting is an irreversible action and data cannot be recovered at a later time.
- An SD memory card having any problem cannot be properly formatted.

Setting Image Resolution and Quality

Resolution and quality settings determine the pixel size (dimension), image file size, and compression ratio for your images. These settings affect the number of images that can be stored. As you get to know the camera, it is recommended that you try each quality and resolution setting to get an appreciation for the effects that these settings will have on your images.

Higher resolution and higher quality images offer the best photographic results, but produce large file sizes. Therefore, few images will take up a lot of memory space.

High resolution and quality settings are recommended for printed output and situations requiring the finest detail. Lower resolution/quality images take up less memory space and may be quite suitable for sharing images via e-mail, in a report, or on a web page.



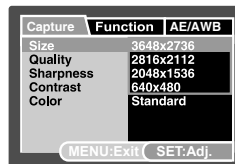
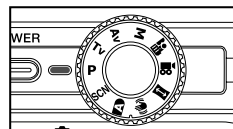

To change image resolution or image quality, perform these steps below:

1. Slide the mode switch to [📷] and set the mode dial to one of the photography modes.
2. Press the **MENU** button.
 - [Capture] of the photography menu is displayed.
3. Select [Size] with the ▲ / ▼ buttons, and press the **SET** button.
4. Select the desired setting with the ▲ / ▼ buttons, and press the **SET** button.
5. Select [Quality] with the ▲ / ▼ buttons, and press the **SET** button.
6. Select the desired setting with the ▲ / ▼ buttons, and press the **SET** button.
7. To exit from the photography menu, press the **MENU** button.



Possible number of shots (still image)

The following table shows the approximate shots that you can capture at each setting based on the capacity of the internal memory and an SD memory card.

Size	Quality	Internal Memory	SD memory card capacity						
			32MB	64MB	128MB	256MB	512MB	1GB	2GB
 3648 x 2736	*** Fine	4	4	9	19	38	76	147	299
	** Standard	7	8	17	35	71	144	277	564
	* Economy	11	12	25	52	104	209	403	819
 2816 x 2112	*** Fine	6	6	14	28	57	115	221	448
	** Standard	11	12	25	51	103	208	400	808
	* Economy	17	19	39	80	160	323	623	1254
 2048 x 1536	*** Fine	9	10	22	45	89	180	347	706
	** Standard	18	19	40	82	164	330	636	1280
	* Economy	27	30	61	124	247	498	959	1921
 640 x 480	*** Fine	65	72	149	301	600	1208	2325	4728
	** Standard	114	126	258	522	1040	2094	4030	7684
	* Economy	155	172	352	712	1418	2856	5496	10246

* The numbers would be different depending on the subjects to be captured.

* The actual recordable number might be more than the estimated recordable number as shown on the above table.

Possible recording time / sec (video clip)

Size	Quality	Internal Memory	SD memory card capacity						
			32MB	64MB	128MB	256MB	512MB	1GB	2GB
 640 x 480	*** Fine	0:28	0:31	1:02	2:08	4:19	8:40	17:21	34:46
	** Standard	0:39	0:43	1:26	2:56	5:57	11:56	23:54	47:53

- * Frame rate of video recording would be different depending on the SD memory card access speed. If using a low access speed SD memory card, it influences the frame rate and recording time.
- * If the access speed of your memory card is not high enough (over 2MB/Sec for random write), the video clip will automatic stop or some unexpected situation may occur while recording. In this case, change into a high-speed memory card or select standard quality.

PHOTOGRAPHY MODE

[**A**] Auto Mode





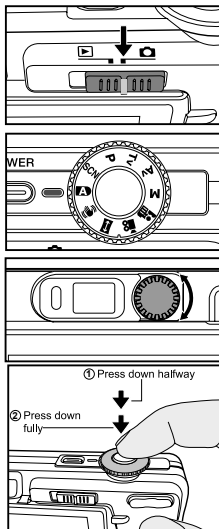





Auto photography mode is the most commonly used photography mode. Images can be captured simply because the exposure (the combination of shutter speed and aperture setting) is determined automatically to suit the photographic conditions. You can use either the optical viewfinder and/or the 2.5" LCD monitor to compose your images. Capturing images using the optical viewfinder will conserve the battery power. If the battery power is low, it is recommended that you only compose images using the viewfinder. Using the LCD monitor, you can compose images more accurately, but at the cost of the battery consumption. Always use the LCD display for close-up macro shots.

1. Press the **POWER** button to turn on the camera.
2. Slide the mode switch to [**📷**] and set the mode dial to [**A**].
3. Compose your image in the LCD monitor.
 - If you are composing your image in the viewfinder, turn the “diopter adjustment dial” until the image appears clearly within the viewfinder.
4. Press the shutter button down halfway.
 - Pressing the shutter button down halfway automatically focuses and adjusts the exposure.
 - The focus-area frame turns blue and the status LED lights green when the camera is focused and exposure is determined.
 - When the focus or exposure is not suitable, the frame of the focus area turns yellow and the status LED flashes red.
5. Press the shutter button down fully to capture the image.
 - If the photographic preview is set to “On”, images (the captured image) will be displayed while the image is being recorded onto the memory.
 - When the voice memo is set to “On”, [VOICE RECORDING] will be displayed on the screen immediately after the image is captured and voice memo recording will start.
 - Press the shutter button one more time during recording, or wait for 30 seconds, [VOICE RECORD END] will be displayed and the recording will end. A [**🗣️**] icon is displayed with images that have been recorded with a voice memo.



Recording Voice Memos

A voice memo can be recorded once for 30 seconds at still image mode immediately following a still image capture.

- Slide the mode switch to [] and set the mode dial to one of the photography modes, except for [] and [] modes.
- Press the **MENU** button, and select the [Function] menu with the  button.
 - [Function] menu is displayed.
- Select [Dub] with the  /  buttons, and press the **SET** button.
- Select [On] with the  /  buttons, and press the **SET** button.
- Press the **MENU** button to exit from the menu.
 - [] icon is displayed on the screen.
- Compose the image, press the shutter button down halfway, then press it down fully.
 - [VOICE RECORDING] is displayed on the screen immediately, and the voice memo recording starts.
- Press the shutter button one more time during recording, or wait for 30 seconds.
 - [VOICE RECORD END] will be displayed and the recording will end.
 - A [] icon is displayed with images that have been recorded with a voice memo.

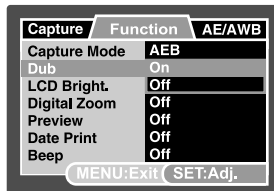



NOTE

- Voice memo is only available in [Single] capture mode.
- Voice memo is automatically fixed at [Off] in [Continuous], [AEB], [Burst], [Pre-Shot] or [Coupling Shot] capture mode.

Using the Optical Zoom

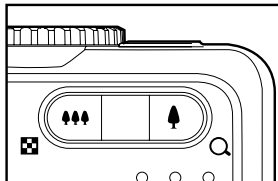

Zoom photography allows you to capture images magnified up to 3 times or wide-angle photography depending on the distance up to the subject. You can also enlarge the center of the screen and capture images in the digital zoom mode.

1. Slide the mode switch to [] and set the mode dial to one of the photography modes.
2. Compose the image with the zoom button.
 - Pressing the  button zooms in on the subject, and enlarges the subject on the LCD monitor.
 - Pressing the  button provides a wider angle image.
 - The lens position moves according to the zoom button setting.
3. Press the shutter button down halfway, then press it down fully.



Using the Digital Zoom

Using a combination of 3 times optical zoom and 10.4 times digital zoom permits zoom photography up to 31.2 times to suit the subject and the distance. While digital zoom can be a useful feature, the more an image is enlarged (zoomed), the more pixelated (grainier) the image will appear.

1. Slide the mode switch to [] and set the mode dial to one of the photography modes, except for [] mode.
2. To enable the digital zoom:
 - a. Press the **MENU** button.
 - b. Select [Function] with the **▶** button.
 - c. Select [Digital Zoom] with the **▲** / **▼** buttons, and press the **SET** button.
 - d. Select [On] with the **▲** / **▼** buttons again, and press the **SET** button.
 - e. Press the **MENU** button to exit from the menu screen.
 - f. To activate the digital zoom, press and hold the **⬆** button completely until the image on the LCD monitor expands.
4. Press the shutter button to capture a “zoomed” image.

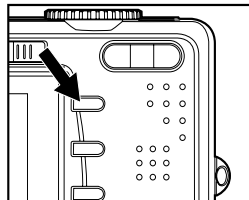

Capture	Function	AE/AWB
Capture Mode		AEB
Dub		Off
LCD Bright.		0
Digital Zoom		On
Preview		Off
Date Print		Off
Beep		Off

MENU:Exit SET:Adj.

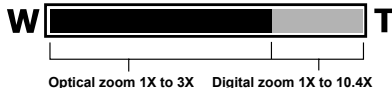



NOTE

- The zoom setting is automatically cancelled by either turning the camera off or the activation of the Auto OFF function.







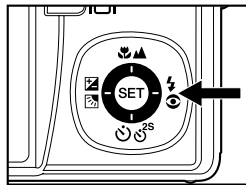





Setting the Flash

Set the flash for capturing images. The flash firing mode can be set to suit for the photographic conditions.



1. Slide the mode switch to [].
2. Toggle the  button to select the desired flash mode.



The table below will help you choose the appropriate flash mode:

Flash mode	Description
[Blank] Auto Flash	The flash fires automatically to suit the photographic conditions. This mode is only available when the camera is set to the [], [], [] and [] mode.
[] Red-eye Reduction	Use this mode to reduce the red-eye phenomenon when you want to capture natural- looking images of people and animals in low-light conditions. When the camera mode is [], [] and [], the flash will fire to suit the brightness of the subject. When the camera mode is [] and [], the flash will always fire.
[] Forced Flash	In this mode, the flash always fires. Use this mode for photographing under artificial light such as backlighting, fluorescent lighting, etc.
[] Flash Off	Use this mode when capturing images using indoor lighting, for stages and indoor competitions, and when the subject is too far away for the flash to be effective.



The available flash settings in different photography modes:



		[Blank] Auto Flash			
Mode Dial	Auto	○	○	○	○
	Program	○	○	○	○
	Shutter Speed Priority	X	○	○	○
	Aperture Priority	X	○	○	○
	Manual	X	○	○	○
	User Setting	○	○	○	○
	Video	X	X	X	X
	Panorama	○	○	○	○
	Anti-Shake	○	○	○	○
Scene Mode	Sport	X	X	X	○
	Portrait	X	○	X	X
	Night Portrait	X	○	X	X
	Night	X	X	X	○
	Candlelight	X	X	X	○
	Fireworks	X	X	X	○
	Landscape	X	X	X	○
	Natural Green	X	X	X	○
	Sunrise	X	X	X	○
	Sunset	X	X	X	○
	Text	X	X	X	○
	Black & White	○	○	○	○
	Sepia	○	○	○	○
	Splash Water	○	○	○	○
	Flowing Water	X	X	X	○
	Pets	○	○	○	○
Capture Mode	Single	○	○	○	○
	Continuous	X	X	X	○
	AEB	X	X	X	○
	Burst	○	○	○	○
	Pre-Shot	○	○	○	○
	Coupling Shot	○	○	○	○
Focus Mode	Normal Auto Focus	○	○	○	○
	Macro	○	○	○	○
	Infinity	X	X	X	○

* This table is for reference only and varies according to different combination of photography modes.

* ○: Available X: Unavailable



Setting the Focus

Images can be captured with the distance to the subject set by Normal Auto Focus, [] Macro or [] Infinity.

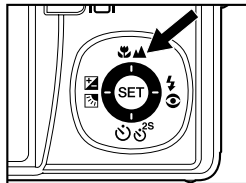
- Slide the mode switch to [] and set the mode dial to one of the photography modes.
 - The available focus settings will depend on the selected photography mode.
- Toggle the  button to select the desired focus mode.



The table below will help you choose the appropriate focus mode:

Focus mode	Description
[Blank] Normal Auto Focus	Select normal auto focus for most occasions when you want the camera to automatically determine the focus setting. Wide: Approximately 0.3m to infinity. Tele: Approximately 0.5m to infinity.
[] Macro	Selects this when you want to capture a close up image. Wide: Approximately 0.05m to infinity. Tele: Approximately 0.3m to infinity.
[] Infinity	Select the infinity-focus setting when you want to capture images of subjects at a distance of infinity.



NOTE

- When you capture a close-up image at macro mode, the resolution of the corner image may be inferior. This is normal and not a malfunction.

Setting the Self-timer





This setting allows images to be captured with the self-timer.



1. Slide the mode switch to [] and set the mode dial to one of the photography modes.

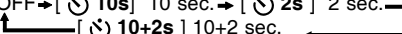

2. Toggle the  button to select the setting.

- Each press of the button moves the icon one step through the sequence and displays it on the screen.

- For [Single] capture mode.

OFF → [ 10s] 10 sec. → [ 2s] 2 sec.
 [ 10+2s] 10+2 sec.

- For [], [], [Continuous], [AEB], [Burst], [Pre-Shot] and [Coupling Shot] capture modes.

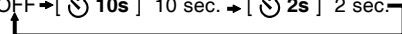

OFF → [ 10s] 10 sec. → [ 2s] 2 sec.

3. Compose the image, press the shutter button down halfway, then press it down fully.

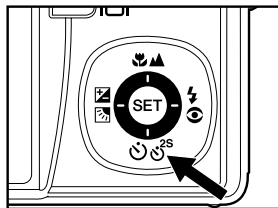
- The self-timer LED flashes and the image will be captured after the preset time has elapsed.
- The countdown is displayed on the LCD monitor.
- To cancel the self-timer during operation, press the **SET** button.





The table below will help you choose the appropriate self-timer mode:

Self-timer mode	Description
[ 10s] 10 sec.	The image is captured about 10 seconds after the shutter button is pressed.
[ 2s] 2 sec.	The image is captured about 2 seconds after the shutter button is pressed.
[ 10+2s] 10+2 sec.	The first image is captured about 10 seconds after the shutter button is pressed, and then the second image is captured 2 seconds later. The 10+2 mode is convenient when capturing group images in succession.











NOTE

- The self-timer setting is automatically cancelled after an image is captured.
- Use of the [ 2s] or [ 10s] self-timer setting is effective in preventing motion-blur that can result when the shutter button is pressed at long exposure times. Use a tripod for best results.

Exposure Compensation/Backlight Correction

Images can be captured with the overall scene intentionally made brighter or darker. These settings are used when a suitable brightness (exposure) cannot otherwise be obtained in circumstances where the difference in brightness between the subject and the background (the contrast) is large, or when the subject that you wish to capture is very small within the scene. Exposure can be set in 1/3 EV units.

1. Slide the mode switch to [] and set the mode dial to [P], [TV], [Av], [], [] or [] and press the [] button.

- Each press of the [] button displays the setting in the order of [] Backlight Correction and [] Exposure Compensation.

2. Set the exposure value with the ▲ / ▼ buttons.

- Press the ▲ button to increase the value.
- Press the ▼ button to decrease the value.
- The setting range of the exposure compensation is as follows:-2.0, -1.7, -1.3, -1.0, -0.7, -0.3, 0, +0.3, +0.7, +1.0, +1.3, +1.7, +2.0.
- Press the [] button to confirm the setting.
- The larger the value, the brighter the image. The smaller the value, the darker the image. The set value is displayed on the screen.

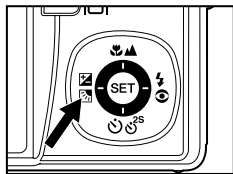

Effective Subjects and Set Values

- + (positive) compensation
 - * Printed matter comprising black text on whitish paper
 - * Backlighting
 - * Bright scenes or strong reflected light such as ski slopes
 - * When the sky accounts for a large area on the screen
- - (negative) compensation
 - * People illuminated by a spotlight, in particular, against dark background

- * Printed matter comprising white text on blackish paper
- * Weak reflecting bodies such as evergreen trees or darkish leaves
- Backlight correction (+1.3 EV, fixed)
 - * When the background is bright and the subject is dark.
 - * When subjects (people) have a light source such as the sun to their backs.



NOTE

- For [A] mode, only backlight correction can be set.







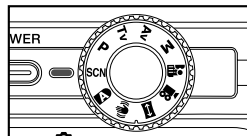







[SCN] Scene Mode

By simply selecting one of the following 16 modes, you can capture the image with most appropriate settings.

1. Slide the mode switch to [] and set the mode dial to [SCN].
 - a. Press the **MENU** button.
 - b. Select [Scene Mode] with the ▲/▼ buttons, and press the **SET** button.
 - c. Select the desired scene mode with the ▲/▼ buttons, and press the **SET** button.
2. Compose the image, press the shutter button down halfway, and then press it down fully.



The table below will help you choose the appropriate scene mode:

Scene mode	Description
[] Sport	Select this mode when you want to capture fast-moving subjects.
[] Portrait	Select this mode when you want to capture an image that makes the person stand out against a defocused (blurred) background.
[] Night Portrait	Select this mode when you want to capture people with an evening or night scene background.
[] Night	Select this mode when you want to capture dark scenes such as night views.
[] Candlelight	Select this mode when you want to capture images of candlelit scene, without spoiling the atmosphere.
[] Fireworks	Select this mode when you want to capture fireworks clearly with optimal exposure. The shutter speed becomes slower, so using a tripod is recommended.
[] Landscape	Select this mode when you want to capture landscape images with bright color.
[] Natural Green	Select this when you want to capture the green scenery background such as forest.
[] Sunrise	Select this mode when you want to capture images of a scene at sunrise. This mode helps keep the deep hues in the scene.
[] Sunset	Select this mode when you want to capture images of a scene at sunset. This mode helps keep the deep hues in the scene.
[TEXT] Text	Select this mode when you want to capture an image that contains black and white subjects like printed documents.
[] Black & White	Select this mode when you want to capture a black & white image.
[] Sepia	Select this mode when you want to capture a sepia image.
[] Splash Water	Select this mode when you want to capture images of splashing water.
[] Flowing Water	Select this mode when you want to capture the soft flowing water. Shutter speed is automatically slowed down while maintaining proper exposure, which produces an image with the water blurred into smooth flowing lines along with a sharply focused background.
[] Pets	Select this mode when you want to capture your pets. Shoot from the eye level of your pets.

The available capture modes in different scene modes:

	Single	Continuous	AEB	Burst	Pre-Shot	Coupling Shot	Remark
Sport	○	○	○	○	X	X	
Portrait	○	○	○	○	○	X	*1
Night Portrait	○	X	X	X	○	○	
Night	○	○	○	○	X	X	
Candlelight	○	○	○	○	○	○	
Fireworks	○	X	X	X	X	X	
Landscape	○	○	○	○	X	X	
Natural Green	○	○	○	○	○	○	*1
Sunrise	○	○	○	○	X	X	
Sunset	○	○	○	○	X	X	
Text	○	○	○	○	X	X	
Black & White	○	○	○	○	○	○	*1
Sepia	○	○	○	○	○	○	*1
Splash Water	○	○	○	○	○	○	*1
Flowing Water	○	○	○	○	X	X	
Pets	○	○	○	○	X	X	*1

* 1: In [Continuous] or [AEB] capture mode, the flash is automatically fixed at "OFF".

[P] Program (Automatic Exposure) Photography Mode

The camera automatically sets the shutter speed and the aperture to suit the brightness of the subject. This allows you to capture image with ease just like when the [M] mode is selected.

1. Slide the mode switch to [] and set the mode dial to [P].
2. Compose the image, press the shutter button down halfway, then press it down fully.

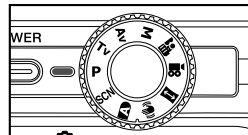







NOTE

- Exposure compensation and backlight correction can be set.



[Tv] Shutter Speed Priority Photography Mode

In this mode, images are captured with the priority given to shutter speed. The aperture is automatically set according to the shutter speed. If you set a fast shutter speed, you can capture images of moving subjects that look as if they are still. If you set a slow shutter speed, you can capture images that give the impression that the subject is in motion.

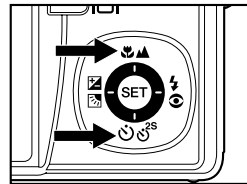
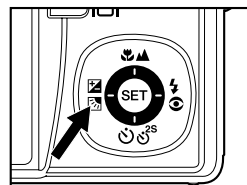
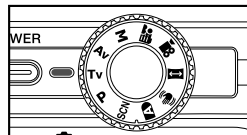
1. Slide the mode switch to [] and set the mode dial to [Tv].
2. Press the  button.
3. Adjust the shutter speed with the  /  buttons.
 - Press the  button to select faster shutter speeds.
 - Press the  button to select slower shutter speeds.
 - The setting range of the shutter speed is as follows:
1/1500, 1/1250, 1/1000, 1/820, 1/650, 1/500, 1/400, 1/320, 1/250, 1/200, 1/160, 1/125, 1/100, 1/80, 1/64, 1/50, 1/40, 1/32, 1/25, 1/20, 1/16, 1/13, 1/10, 0.13s, 0.16s, 0.2s, 0.25s, 0.3s, 0.4s, 0.5s, 0.6s, 0.8s, 1.0s.
 - The shutter speed and corresponding aperture value are displayed on the screen. If an appropriate combination cannot be set, the aperture value is displayed in red, but images can be captured regardless.
4. Compose the image, press the shutter button down halfway, and then press it down fully.









NOTE

- In the flash photography mode, when [] and [] are set, the fastest shutter speed is 1/500 second.

[Av] Aperture Priority Mode

In this mode, images are captured with the priority given to aperture. The shutter speed is automatically set according to the aperture. The aperture will affect the depth-of-field of the camera.

If you set a small aperture (higher F value), both close objects and distant objects will be in focus, for example when capturing landscape images. Alternatively, if you set a large aperture (lower F value), you can capture portrait images with an out-of-focus background.

1. Slide the mode switch to [] and set the mode dial to [Av].
2. Press the  button.
3. Adjust the aperture with the  /  buttons.
 - Press the  button to increase the value.
 - Press the  button to decrease the value.
 - The setting range of the aperture value is as follows:
F6.7, F5.6, F4.8, F4.0, F3.5, F2.8 (Wide).
F4.8, F5.6, F6.7, F8.0, F9.5, F11.0 (Tele).
 - The aperture value and corresponding shutter speed are displayed on the screen. If an appropriate combination cannot be set, the shutter speed is displayed in red, but images can be captured regardless.
4. Compose the image, press the shutter button down halfway, and then press it down fully.

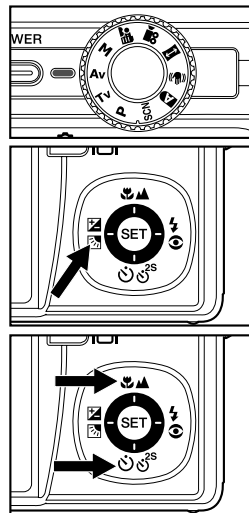





NOTE

- The aperture value varies depending on the position of the zoom lens.



[M] Manual Mode

In manual mode, the aperture value and the shutter speed can be varied individually.

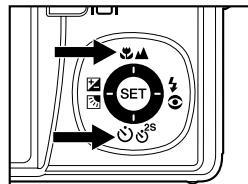
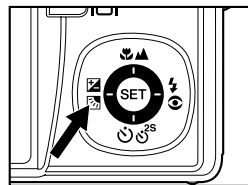
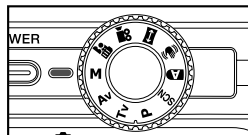
1. Slide the mode switch to [] and set the mode dial to [M].
2. Toggle the  button to select the shutter speed or aperture.
3. Adjust the shutter speed or aperture with the  /  buttons.
4. Compose the image, press the shutter button down halfway, and then press it down fully.





NOTE

- In the flash photography mode, when [] and [] are set, the fastest shutter speed is 1/500 second.

[] User Setting Mode

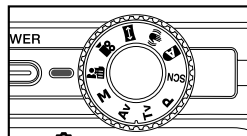

This mode allows you manually set the setting parameters and all these settings will be memorized.

1. Slide the mode switch to [] and set the mode dial to [].
2. Compose the image, press the shutter button down halfway, then press it down fully.



[] Video Mode

This mode allows you to record video clips at a resolution of 640 x 480 pixels. Voice can also be recorded.

1. Slide the mode switch to [] and set the mode dial to [].
2. Compose the scene with the zoom button.
 - Optical and digital zoom can be used while composing the scene.
3. Fully press down the shutter button.
 - The recording of the video clip will start.
 - Pressing the shutter button again will end the recording.
 - The recording time depends on the storage size and the subject of the image to be recorded.
 - Zoom function cannot be used during video recording.

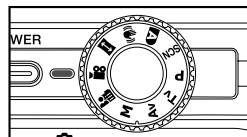



NOTE

- When recording video clips, the flash cannot be used.
- If the access speed of your SD memory card is not enough for recording video clips in the currently selected quality, a warning icon [] will appear, and then the video recording will stop. In this case, select a video quality lower than the current one.

[] Panorama Mode

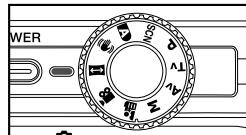

This mode is designed to make it easier to capture a series of shots then stitch them together with software to make a single image. You can capture a photographic subject that won't fit into a single frame, such as a landscape, and stitch it together later with a program such as Cool 360 or Photoshop application.

1. Slide the mode switch to [] and set the mode dial to [].
2. Shoot the first image.
 - The next image appears beside the previous image.
3. Orient the camera so that the second frame overlaps a small portion of the photographic subject of the first image and press the shutter button to capture the next image.
4. Follow the same steps to capture subsequent images in the sequence.
5. Finish the sequence by pressing the **SET** button after the last image has been recorded.



[] Anti-Shake Mode

The anti-shake function works according to the luminance of the target object. This function uses special image data processing for getting high sensitivity of CCD. High sensitivity can use higher shutter speed compared with normal mode, so it reduces influence of hand shaking. From the resolution point of view, it becomes worse than normal mode. Maximum size of image becomes 6 megapixels (2816 x 2112).

1. Slide the mode switch to [] and set the mode dial to [].
2. Compose the image, press the shutter button down halfway, then press it down fully.

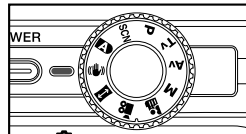

Recording a Subject onto an Existing Background Image (Pre-Shot)

Pre-Shot helps you get the background you want, even if you need to ask someone else to record the image for you. Basically, Pre-Shot is a two-step process.

1. You compose the background you want and press the shutter button, which causes a semi-transparent image of the background to remain on the monitor screen.
2. Ask someone else to record a shot of you against your original background, telling him/her to compose the image by using the semi-transparent monitor screen image as a guide.
 - The camera stores the image produced by step 2 only.
 - Depending on how the image is actually composed in step 2, its background may not be exactly the same as the one you composed in step 1.

Freeze the background on the monitor screen.

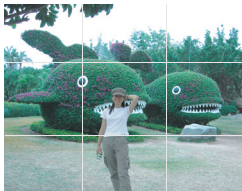

Record the image, using the background on the monitor screen as a guide.



Only the second image is recorded.



1. Slide the mode switch to [📷] and set the mode dial to one of the photography modes, except for [📹], [📷] and [📷].
 - a. Press the **MENU** button.
 - b. Select [Function] with the ► button.
 - c. Select [Capture Mode] with the ▲/▼ buttons, and press the **SET** button.
 - d. Select [Pre-Shot] with the ▲/▼ buttons, and press the **SET** button.
2. Compose the background you want on the monitor screen, and then press the shutter button to temporarily record it as a reference image.
 - This operation causes a semi-transparent image of the background to appear on the monitor screen, but the displayed image is not actually saved in camera memory.
3. Now you can stand in front of the background and ask someone else to snap your picture, using the semi-transparent background on the monitor screen as a composition guide.
4. After composing the final image (using the semi-transparent background as a guide), the person with the camera should press the shutter button to record.
 - Note that the semi-transparent background image you temporarily record in step 2 is for composition purposes only. The final image contains only what is in front of the camera when the shutter button is pressed in step 4.

Combining Shots of Two People into a Single Image (Coupling Shot)

The Coupling Shot mode lets you record images of two people and combine them into a single image. This makes it possible for you to include yourself in group images, even when there is no one else around to record the image for you.

First Image

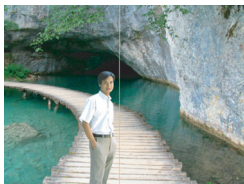

This is the part of the image that does not include the person who is recording the first image.

Second Image



Making sure that the background of the image is aligned correctly, record the image of the person who recorded the first image.

Combined Images







- Slide the mode switch to and set the mode dial to one of the photography modes, except for , and .
 - Press the **MENU** button.
 - Select [Function] with the **▶** button.
 - Select [Capture Mode] with the **▲/▼** buttons, and press the **SET** button.
 - Select [Coupling Shot] with the **▲/▼** buttons, and press the **SET** button.
- Align the focus frame on the screen with the subject you want on the left side of the image.
- Press the shutter button to record the left side of the image.
- Next compose the subject you want in the right side of the image, taking care to align the actual background with the semi-transparent image of the background of the first image, which is shown on the screen.
- When everything is aligned correctly, record the right side of the image.

[] PLAYBACK MODE

Playing Back Still Images

You can play back the still images on the LCD monitor.

1. Slide the mode switch to [].
 - The last image appears on the screen.
2. The images can be displayed in reverse or forward with the  /  buttons.
 - To view the previous image, press the  button.
 - To view the next image, press the  button.

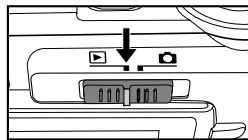

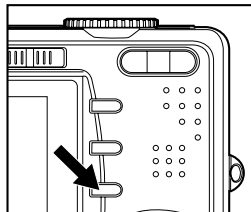







Image Display Information

You can switch the information display by pressing the  button when playing back images. Each press of the  button switches the information display state in the following order:





NOTE

- Pressing the  /  buttons during image playback will rotate the image 90 degrees.
- The  button rotates the image clockwise, whereas the  button rotates the image counterclockwise. A press of the button opposite to the direction in which the image was rotated will return the image to the normal display.
- A  icon is displayed with the video data. Video clips cannot be rotated.
- A  icon is displayed with images which have an audio memo recorded.
- Press the **SET** button to play back voice memos. Press it again to stop voice memo playback.

Playing Back Video Clips

You can play back recorded video clips on the LCD monitor. You can also play back voice.

- Slide the mode switch to [].
 - The last image appears on the screen.
- Select the desired video clip with the ◀ / ▶ buttons.
 - A [] icon is displayed with the video data.
- Press the **SET** button to play back a video clip.
 - Pressing the ▶ / ◀ buttons during playback initiates fast forward/fast reverse.

Button Operations

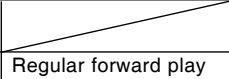
	During Playback	During a Pause	During a Stop
▶ button	(Forward play) Pressing the ▶ button will sequentially invoke 2x fast-forward, 4x fast-forward, regular play.	1-frame feed	The next image is displayed.
◀ button	(Reverse play) Pressing the ◀ button will sequentially invoke 2x fast-reverse, 4x fast- feed reverse, regular play.	Reverse 1-frame	The previous image is displayed.
▲ button	Sound On/Off		
▼ button	Stop (The display returns to the 1st frame playback).		
SET button	Pause	Cancel pause	Regular forward play



- Video clips cannot be displayed rotated or enlarged.

Playing Back Still Images/Video Clips on a TV

You can also play back your images on a TV screen. Before connecting to any video devices, make sure to select NTSC/PAL to match the broadcast standard of the video equipment you are going to connect to the camera. Using the AC power adapter is recommended when transferring the recorded images and video files.

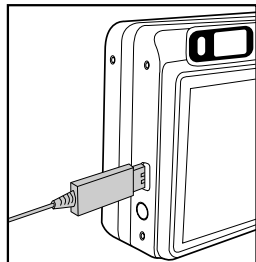

1. Slide the mode switch to [].
2. Connect one end of the A/V cable to the A/V OUT terminal of the camera.
3. Connect the other end to the A/V input socket of the TV set.
4. Turn the TV and camera on.
5. Play back the still images/video clips.
 - The method of operation is the same as playing back still images and video clips on the camera.



- Refer to the section in this manual titled “Video Output” in the Setup2 Menu for further details.

Attaching Voice Memos

A maximum of 30 seconds of audio can be recorded like a memo annotation for each still image. The voice memo can be recorded only once.

1. Slide the mode switch to [].
 - The last image appears on the screen.
2. Select the image where you want to attach the voice memo with the ◀ / ▶ buttons.
3. Press the **MENU** button.
4. Select [Setup1] with the ▶ button.
5. Select [Voice Memo] with the ▲ / ▼ buttons, and press the **SET** button.
6. Select [On] with the ▲ / ▼ buttons, and press the **SET** button.
7. Press the **MENU** button to exit from the menu.
8. Press the shutter button.
 - [VOICE RECORDING] is displayed on the screen and recording starts.
9. To stop recording voice memo during recording, press the shutter button again.
 - [VOICE RECORD END] will be displayed and the recording will end.
 - A [] is displayed with images that have been recorded with a voice memo.

Playing back voice memo

Pressing the **SET** button displays [VOICE PLAYBACK] and plays back the voice memo. Pressing it again stops voice memo playback.



- Voice memo is only available for still images.
- If a voice memo has already been recorded (either by dub recording or attaching voice memo afterwards), the voice memo can not be replaced or recorded again.

Thumbnail Display



This function allows you to view 9 thumbnail images on the LCD monitor at the same time which can help to quickly search for the image that you want.

1. Slide the mode switch to [].
 - The last image appears on the screen.
2. Press the ******* button.
 - The images are displayed in the thumbnail display.
 - Images that have been selected with the **▲ / ▼ / ◀ / ▶** buttons will be indicated by a green frame.
 - When there are ten or more images, scroll the screen with the **▲ / ▼** buttons.
3. Press the **▲ / ▼ / ◀ / ▶** buttons to select the image to be displayed at regular size.
4. Press the **SET** button.
 - The selected image is displayed at its regular size.







Page Jump Function

This function allows you to select the image to be displayed immediately from a lot of recorded images.

1. Slide the mode switch to [].
2. Press the ******* button to enter thumbnail display.
3. Press the  button to enter page jump function and the image is indicated by a red frame.
4. For page selection, follow the steps below:
 - Pressing the **▲** button jumps to the first image.
 - Pressing the **▼** button jumps to the last image.
 - Pressing the **◀** button jumps to the previous thumbnail page.
 - Pressing the **▶** button jumps to the next thumbnail page.
5. Press the  button to resume normal thumbnail display.
 - To select the image to be displayed at regular size, follow the steps 3-4 in the above section.



NOTE

■ A , , ,  icon will be displayed in a thumbnail display.

Zoom Playback

This mode also allows you to enlarge your image on the selected portion of the image to check for small details.

1. Slide the mode switch to [].
2. Press the ◀ / ▶ buttons to select the image you want to enlarge.
 - You can also select the image you want to enlarge from the thumbnail display.
3. Adjust the zoom ratio with the ⬆ / *** buttons.
 - Pressing the ⬆ button enlarges the image.
 - To return to normal magnification, press the *** button.
 - The magnification factor is displayed on the LCD monitor.
 - The image is displayed enlarged, and a white frame and green frame are displayed on the LCD monitor.
 - The white frame indicates the entire image, while the green frame shows the location of the currently enlarged area.
4. Press the ▲ / ▼ / ◀ / ▶ buttons to select the area to enlarge.
5. To return to regular display, toggle the *** button until the regular display appears on the screen.



Entire image Current position of enlargement



NOTE

- Pressing the ⬆ button magnifies the image from 1x → 2x → 4x → 8x.
- Pressing the *** button reduces the image from 8x → 4x → 2x → 1x.

Slideshow Display

The slideshow function enables you to play back your still images automatically in sequential order as a slideshow. This is very useful and entertaining feature for reviewing captured images and for presentations.

1. Slide the mode switch to [].
2. Press the **MENU** button.
 - The playback menu is displayed.
3. Select [Slide Show] with the **▲** / **▼** buttons, and press the **SET** button.
 - The slideshow starts.
4. To stop the slide show during playback, press the **SET** button.
 - The image is displayed on screen when you press the **SET** button.

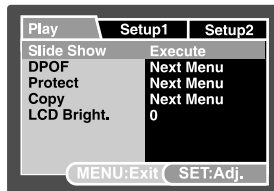



NOTE

- The Auto OFF function does not operate during slide show.
- All still images in the folder are automatically played back.

Protecting Images

Set the data to read-only to prevent images from being erased by mistake.

Protecting Images

1. Slide the mode switch to [].
2. Select the image that you want to protect with the ◀ / ▶ buttons.
3. Press the **MENU** button.
 - The playback menu is displayed.
4. Select [Protect] with the ▲ / ▼ buttons, and press the **SET** button.
5. Select [Single] or [All] with the ▲ / ▼ buttons, and press the **SET** button.
6. Select [Set] with the ▲ / ▼ buttons, and press the **SET** button.
 - Protection is applied to the image and the camera returns to the playback mode.
 - The protect icon [] is displayed with protected images.
When [All] has been selected, [] is displayed with all the images.

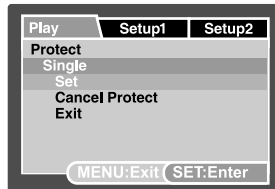
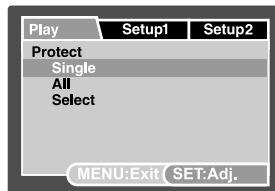
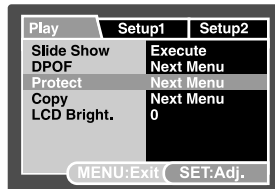

Canceling the Protection

To cancel protection, display the image that you want to remove the image protection.

1. Select [Protect] with the ▲ / ▼ buttons from the playback menu, and press the **SET** button.
2. Select [Single] or [All] with the ▲ / ▼ buttons, and press the **SET** button.
3. Select [Cancel Protect] with the ▲ / ▼ buttons, and press the **SET** button.
 - The removal of image protection is executed and the camera returns to the playback mode.

Protecting multiple images simultaneously

1. Select [Protect] with the ▲ / ▼ buttons from the playback menu, and press the **SET** button.
2. Select [Select] with the ▲ / ▼ buttons, and press the **SET** button.
 - The images are displayed in the thumbnail display.
3. Select the image you want to protect with the ▲ / ▼ / ◀ / ▶ buttons, and press the [□] button.
 - The protect icon [🔒] is displayed with protected images. Selecting a protected image and pressing the [□] button again will cancel the protection. This procedure is repeated to select multiple images.
4. Press the **SET** button.
 - Protection and cancellation the protection are executed and the camera returns to playback mode.



NOTE

- Formatting an SD memory card (or internal memory) overrides protection, and erases all images regardless of their protected status.

DPOF Settings

DPOF is the abbreviation for Digital Print Order Format, which allows you to embed printing information on your memory card. You can select the images to be printed and how many prints to make with the DPOF menu in the camera and insert the memory card to the card compatible printer. When the printer starts printing, it will read the embedded information on the memory card and print the specified images.

1. Set the mode dial to [].
2. Select the image that you want to set DPOF with the ◀ / ▶ buttons.
3. Press the **MENU** button.
 - The playback menu is displayed.
4. Select [DPOF] with the ▲ / ▼ buttons, and press the **SET** button.
 - The DPOF setting screen is displayed.
5. Select [Single] or [All] with the ▲ / ▼ buttons, and press the **SET** button.
 - [Single]: Sets DPOF for each individual image.
 - [All]: Sets DPOF for all images at once.
6. Select [Print Num.] with the ▲ / ▼ buttons, and press the **SET** button.
 - This displays the number of prints setting screen.
7. Set the number of prints with the ▲ / ▼ buttons, and press the **SET** button.
 - You can set up to 9 prints for each image.
8. Select [Date] with the ▲ / ▼ buttons, and press the **SET** button.
 - The date setting screen appears.

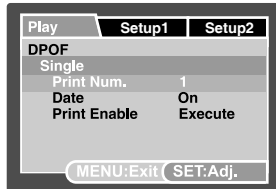
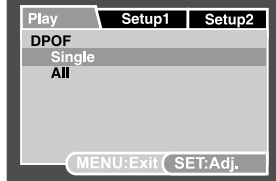
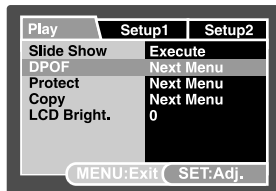

9. Select date to [On] or [Off] with the ▲ / ▼ buttons, and press the **SET** button.
- [On]: The date of the image will also be printed.
 - [Off]: The date of the image will not be printed.
10. Select [Print Enable] with the ▲ / ▼ buttons, and press the **SET** button.
11. Select [Execute] with the ▲ / ▼ buttons, and press the **SET** button.
- This creates a file containing the DPOF information, and when the operation is finished, the screen returns to the playback mode.
 - The DPOF icon [] is displayed on each image that has set up DPOF settings.



NOTE

- The date that is printed on the image is the date set on the camera. To print the correct date on the image, set the date on the camera before you capture the image. Refer to section in this manual titled “Setting the Date and Time” for further details.
- For DPOF settings on images stored in the internal memory, be sure to copy those files to an SD memory card first. Refer to section in this manual titled “Copying Files from Internal Memory to a Memory Card” for further details.

Copying Files from Internal Memory to a Memory Card

This function allows you to copy your files from the digital still camera's internal memory to a memory card. Of course, you can only do this if you have a memory card installed and some files in internal memory.

1. Set the mode dial to [].
2. Select the image that you want to copy to a memory card with the ◀ / ▶ buttons.
3. Press the **MENU** button.
 - The playback menu is displayed.
4. Select [Copy] with the ▲ / ▼ buttons, and press the **SET** button.
5. Select [Execute] with the ▲ / ▼ buttons, and press the **SET** button.
 - To not copy, select [Cancel] with the ▲ / ▼ buttons, and press the **SET** button.

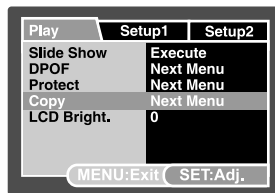

Changing the Camera Start Logo Image

You can specify the start logo image for your camera. You can select the new start logo image among the captured still images.

1. Slide the mode switch to [].
2. Select the image that you want to protect with the ◀ / ▶ buttons.
3. Press the **MENU** button.
 - The playback menu is displayed.
4. Select [Setup1] with the ▶ button.
5. Select [Start Logo] with the ▲ / ▼ buttons, and press the **SET** button.
6. Select [User Image] with the ▲ / ▼ buttons, and press the **SET** button.
7. Select [Execute] with the ▲ / ▼ buttons, and press the **SET** button.
 - This new start logo image will be activated on the next time you turn on the camera.

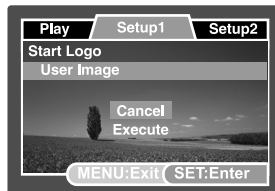



NOTE

- User selected image is saved in the root directory of the internal memory. In case of formatting the internal memory, the user selected start logo image will be lost and replaced with the default start logo image.
- If user replaces start up image through USB (Mass storage device class), and that image is not fit in data format, the start up screen will be broken.
- "NO IMAGE" message is displayed when "User Image" is selected and no images are stored in the SD memory card or internal memory.
- "MEDIA FULL" message is displayed when the free space on the internal memory is insufficient for saving user-selected image.
- If the image recorded voice memo is selected to be the start logo image, the voice memo function will fail.
- The capacity for saving user image is only one. The previous start logo image will not be recovered if you select another one as a new start logo image.

[] Deleting Images

Immediate Erasure (Quick Delete Function)

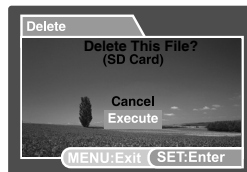
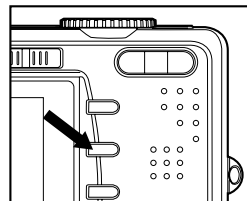
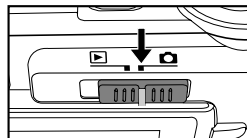

The quick delete function enables you to delete the last-captured image during capture.

1. Slide the mode switch to [] and set the mode dial to one of the photography modes.
2. Press the  button.
 - The last image and quick delete menu appear on the screen.
3. Press the  button again to delete the image.
 - You may also press the **SET** button to confirm the deletion.
 - To not delete, select [Cancel], and press the **SET** button.



Deleting in Playback Mode

Deleting a single image/Deleting all images

1. Slide the mode switch to [].
 - The last image will be displayed on the screen.
2. Select the image you want to erase with the ◀ / ▶ buttons.
3. Press the  button.
 - The deletion menu will be displayed.
4. Select [Single] or [All] with the ▲ / ▼ buttons, and press the **SET** button.
 - [Single]: Erases the selected image or the last image.
 - [All]: Erases all of the images except for the protected images.
 - [Select]: Erases a number of selected images.
5. Select [Execute] with the ▲ / ▼ buttons, and press the **SET** button.
 - To not erase, select [Cancel], and press the **SET** button.

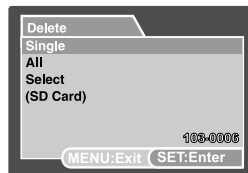
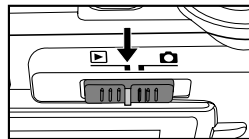











NOTE

- Deleting an image will not affect sequential image numbering. For example, if you delete image number 240, the next captured image will be numbered 241 even though 240 no longer exists. In other words, an image-number is retired when an image is deleted and will not be reused or reassigned to another subsequently captured image.

Deleting selected images

This deletes a number of selected images.

1. Slide the mode switch to [].
2. Press the  button.
 - The deletion menu will be displayed.
3. Select [Select] with the  /  buttons, and press the **SET** button.
 - The images are displayed in the thumbnail display.
4. Select the image you want to erase with the  /  /  /  buttons, and press the  button.
 - The [] icon will be displayed. One more press of the  button will cancel the operation. Repeat this procedure and select all the images that you want to erase.
5. Press the **SET** button.

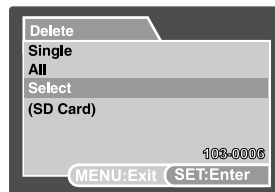

MENU OPTIONS

Photography Menu (Capture tab)

This menu is for basic settings used when capturing images in the photography modes. These settings are retained even if the camera is turned off or the Auto OFF function is activated.

Available menu options in each photography mode:

Auto

Capture	Function
Size	Capture Mode
Quality	Dub
Sharpness	LCD Bright.
Contrast	Digital Zoom
Color	Preview
	Date Print
	Beep

Scene

Capture	Function
Scene Mode	Capture Mode
Size	Dub
Quality	LCD Bright.
	Digital Zoom
	Preview
	Date Print
	Beep

Program / Tv / Av / M / User Setting

Capture	Function	AE/AWB
Size	Capture Mode	White Balance
Quality	Dub	Manual WB
Sharpness	LCD Bright.	ISO
Contrast	Digital Zoom	Metering
Color	Preview	Focus Area
	Date Print	Flash Offset
	Beep	

Video

Capture	Function	AE/AWB
Quality	LCD Bright.	White Balance
Contrast	Digital Zoom	Manual WB
Color	Beep	

Panorama

Capture	Function	AE/AWB
Size	LCD Bright.	White Balance
Quality	Beep	Manual WB
Sharpness		ISO
Contrast		Metering
Color		Flash Offset

Anti-Shake

Capture	Function	AE/AWB
Size	Dub	White Balance
Quality	LCD Bright.	Manual WB
Sharpness	Digital Zoom	Metering
Contrast	Preview	Focus Area
Color	Date Print	Flash Offset
	Beep	

1. Slide the mode switch to [] and set the mode dial to one of the photography modes.
2. Press the **MENU** button.
 ■ [Capture] menu is displayed.
3. Select the desired [Capture] option item with the **▲** / **▼** buttons, and press the **SET** button to enter its respective menu.
4. Select the desired setting with the **▲** / **▼** buttons, and press the **SET** button.
5. To exit from the menu, press the **MENU** button.

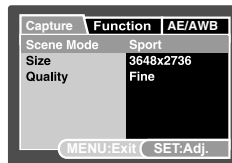
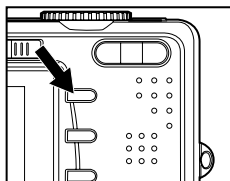
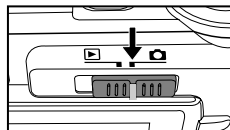





Scene Mode

Refer to section in this manual titled “Scene Mode” for further details.

Size (resolution)

This sets the resolution of the still-image that will be captured.

- * [] 3648 x 2736
- * [] 2816 x 2112
- * [] 2048 x 1536
- * [] 640 x 480

Quality

This sets the quality (compression rate) at which the image is captured.

- * Fine / Standard / Economy



NOTE

- [Economy] setting is not available for [S&L] mode.

Sharpness

The camera can automatically emphasize the borders between light and dark areas of the image. This will make the image's edges look sharper. In some scenes you may prefer sharper edge detail. In other scenes you may prefer softer edge detail.

This sets the sharpness of the image that will be captured.

- * Hard / Normal / Soft

Contrast

This sets the difference between the bright and dark portions of the images that will be captured.

- * Hard / Normal / Soft

Color

This sets the color of the image that will be captured.

- * Standard / Vivid / Sepia / Monochrome / Red / Green / Blue / Yellow / Purple



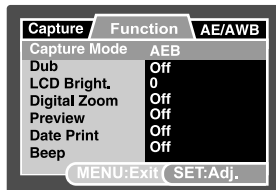

Photography Menu (Function tab)

- Slide the mode switch to [] and set the mode dial to one of the photography modes.
- Press the **MENU** button, and select the [Function] menu with the **▶** button.
 - The [Function] tab of the photography menu is displayed.
- Select the desired [Function] option item with the **▲** / **▼** buttons, and press the **SET** button to enter its respective menu.
- Select the desired setting with the **▲** / **▼** buttons, and press the **SET** button.
- To exit from the photography menu, press the **MENU** button.



Capture Mode

This sets the recording method at the time of capturing images.

- * [**Blank**] Single: Capture an image at a time.
- * [] Continuous: Permits continuous photography of 3 images max.
- * [**AEB**] AEB: Permits 3 consecutive images in the order of standard exposure, underexposure and overexposure compensation.
- * [] Burst: Permits continuous photography while pressing holding the shutter button. As long as you hold the shutter button pressed, images are captured until the memory capacity is exhausted.
- * [] Pre-Shot: Pre-shot helps you get the background you want, even if you need to ask someone else to record the image for you. Basically, Pre-shot is a two-step process.
- * [] Coupling Shot: The Coupling Shot mode lets you record images of two people and combine them into a single image. This makes it possible for you to include yourself in group images, even when there is no one else around to record the image for you.



- In [Continuous], [AEB], [Burst], [Pre-Shot] and [Coupling Shot] capture mode, the voice memo is automatically fixed at [Off].

Dub

Refer to section in this manual titled "Recording Voice Memos" for further details.

- * On / Off



- When [Preview] is set to [Off], [Dub] setting is also fixed at [Off].

LCD Bright.

Select a brightness level for the LCD monitor. The LCD becomes brighter with the ▲ button and darker with the ▼ button. The adjustment range is from -5 to +5.

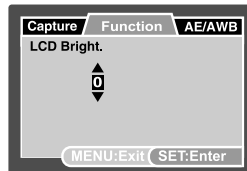

Digital Zoom

This sets whether or not to use digital zoom at the time of photography.

* On / Off

Preview

This sets whether or not to display the captured image on the screen immediately after the image is captured.

* On / Off



NOTE

- When [Preview] is set to [Off], [Dub] setting is also fixed at [Off].

Date Print

The date and time of recording can be printed directly on the still images. This function must be activated before the image is captured.

* On / Off

Beep

Enables or disables the sounds (beeps) associated with camera button functions.

* On / Off



Date & time imprinted here





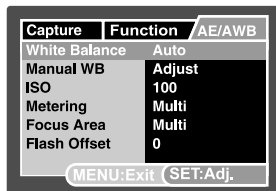

Photography Menu (AE/AWB tab)

1. Slide the mode switch to [] and set the mode dial to one of the photography modes.
2. Press the **MENU** button, and select the [AE/AWB] menu with the **▶** button.
 - The [AE/AWB] tab of the photography menu is displayed.
3. Select the desired [AE/AWB] option item with the **▲** / **▼** buttons, and press the **SET** button to enter its respective menu.
4. Select the desired setting with the **▲** / **▼** buttons, and press the **SET** button.
5. To exit from this menu, press the **MENU** button.



White Balance

This sets the white balance capturing under a variety of lighting conditions and permits images to be captured that approach the conditions that are seen by the human eye.

- * [**Blank**] Auto
- * [] Incandescent
- * [] Fluorescent 1
- * [] Fluorescent 2
- * [] Day Light
- * [] Cloudy
- * [] Manual

Manual WB

This manually sets the white balance and stores it. Use of this is convenient when the white balance does not offer a good match.

Before select [Execute] determine the subject (such as a white paper) that will be used to set the white balance.

- * Cancel / Execute

ISO

This sets the sensitivity for capturing images. When the sensitivity is raised (and the ISO figure is increased), photography will become possible even in dark locations, but the more pixelated (grainier) the image will appear.

* 64 / 100 / 200 / 400 / Auto





NOTE

- In the [Auto] setting, the ISO value is automatically selected from ISO 64 to ISO 200.
- In the [M] mode, the ISO function cannot be used. And the ISO setting will be automatically set between ISO 64 and ISO 400.
- [Auto] setting is not available for [Tv], [Av] and [M] mode.

Metering

This sets the metering method for calculating the exposure.

- * [] Multi: The entire area of the screen is measured, and the exposure is calculated.
- * [] Spot: A very small portion of the center of the screen is measured, and the exposure is calculated.
- * [] Average: The exposure is measured all of the image area.

Focus Area

This sets the focusing area.

- * Multi: The function of auto focus finds the best proper position from 9 blocks of focus area.
- * Center: The function of auto focus adjusts focus at the center of image.

Flash Offset

This sets the flash strength. The flash power becomes strong when selecting "+" values. The flash power becomes soft when selecting "-" values.

* +2 / +1 / 0 / -1 / -2

Playback Menu

In the [] mode, set which settings are to be used for playback.

1. Slide the mode switch to [].
2. Press the **MENU** button.
 - The playback menu is displayed.
3. Select the desired option item with the **▲** / **▼** buttons, and press the **SET** button to enter its respective menu.
4. Select the desired setting with the **▲** / **▼** buttons, and press the **SET** button.
5. To exit from the menu, press the **MENU** button.

Slide Show

Refer to section in this manual titled “Slideshow Display” for further details.

DPOF

Refer to section in this manual titled “DPOF Settings” for further details.

Protect

Refer to section in this manual titled “Protecting Images” for further details.

Copy

Refer to the section in this manual titled “Copying Files from Internal Memory to a Memory Card” for further details.





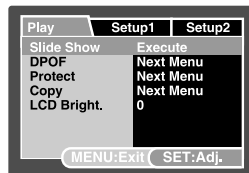
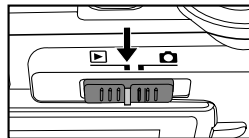

LCD Bright.

Refer to section in this manual titled “LCD Bright.” in Photography Menu (Function tab) for further details.



Setup1 Menu

Set your camera's operating environment.

1. Slide the mode switch to [].
2. Press the **MENU** button, and select the [Setup1] menu with the  button.
 - The [Setup1] menu is displayed.
3. Select the desired setting with the  /  buttons, and press the **SET** button to enter its respective menu.
4. Select the desired setting with the  /  buttons, and press the **SET** button.
5. To exit from the menu, press the **MENU** button.

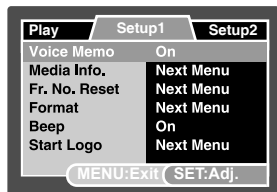

Voice Memo

Refer to section in this manual titled “Attaching Voice Memos” for further details.

Media Info.

This displays the free capacity of the SD memory card (or internal memory). If the SD memory card is not inserted, free capacity of internal memory is displayed.

Fr. No. Reset

This creates a new folder. The captured images are recorded to the newly created folder from number 0001.
* Cancel / Execute

Format

Refer to section in this manual titled “Formatting an SD Memory Card or Internal Memory” for further details.







Beep

Refer to section in this manual titled “Beep” in Photography Menu (Function tab) for further details.

Start Logo

Refer to section in this manual titled “Changing the Camera Start Logo Image” for further details.

Setup2 Menu

1. Slide the mode switch to [].
2. Press the **MENU** button, and select the [Setup2] menu with the  button.
 - The [Setup2] menu is displayed.
3. Select the desired [Setup2] option item with the  /  buttons, and press the **SET** button to enter its respective menu.
4. Select the desired setting with the  /  buttons, and press the **SET** button.
5. To exit from the menu, press the **MENU** button.

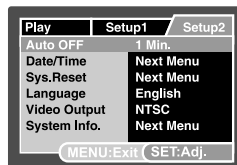

Auto OFF

If no operation is performed for a specific period of time, the power to the camera is automatically turned off. This feature is useful to reduce battery wear.

* 1 Min. / 3 Min. / 5 Min.

Date/Time

Refer to section in this manual titled “Setting the Date and Time” for further details.

Sys. Reset

This returns all basic settings to the camera’s default settings. The time setting will not be reset.

* Cancel / Execute

Language

Refer to section in this manual titled “Choosing the Display Language” for further details.

Video Output

This sets video output system of the video equipment that you are going to connect to the camera.

* NTSC / PAL

System Info.

This displays the firmware version of the camera.

TRANSFERRING RECORDED IMAGES AND VIDEOS TO YOUR COMPUTER

System Requirements (Windows)

- Pentium 166 MHz or higher
- Windows 2000/XP
- 128MB RAM
- 128MB hard disk space
- CD-ROM drive
- Available USB port

System Requirements (Macintosh)

- PowerPC G3/G4
- OS 9.0 or later
- 128MB RAM
- 128MB hard disk space
- CD-ROM drive
- Available USB port

Connecting the Camera to Your Computer

1. Connect one end of the USB cable to the USB terminal of the camera.
2. Connect the other end of the USB cable to an available USB port on your computer.
3. Turn on your camera.
 - The [USB] screen appears.
4. Select [PC] and press the **SET** button.
5. From the Windows desktop, double click on “My Computer”.
6. Look for a new “Removable disk” icon. Typically, the camera will be assigned drive letter “e” or higher.
7. Double click on the removable disk and locate the DCIM folder.
8. Double click on the DCIM folder to open it to find more folders.
 - Your recorded images and video clips will be inside these folders.
 - Copy & Paste or Drag-N-Drop image and video files to a folder on your computer.

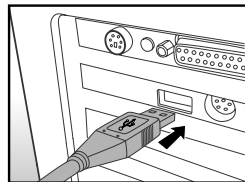
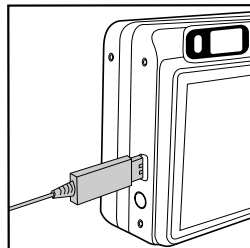

Mac users: Double-click the “untitled” or “unlabeled” disk drive icon on our desktop. iPhoto may automatically launch.



NOTE

- The data saved to the internal memory (memory card) may be damaged if the power to the camera is cut off during image transfer. We recommend that you use the AC power adapter when connecting the camera to the PC.

Downloading Images and Video Files

When the camera is turned on and connected to your computer, it is considered to be a disk drive, just like a floppy disk or CD. You can download (transfer) images by copying them from the “Removable disk” (“untitled” or “unlabeled” disk on a Macintosh) to your computer hard drive.

Windows

Open the “removable disk” and subsequent folders by double clicking on them. Your images are inside these folder(s). Select the images that you want, and then choose “Copy” from the “Edit” menu. Open the destination location (folder) and choose “Paste” from the “Edit” menu. You may also drag and drop image files from the camera to a desired location.

Macintosh

Open the “untitled” disk icon, and the destination location on your hard disk. Drag and drop from the camera to the desired destination.



NOTE

- Do not open the battery cover during USB cable connection.
- Memory card users may prefer to use a memory card reader (highly recommended).
- A video playback application is not included with the package. Make sure that a video playback application has been installed in your computer.
- If you cannot download images/video clips stored in the internal memory, you may copy those files to an SD memory card first and then transfer to your computer. Refer to section in this manual titled “Copying Files from Internal Memory to a Memory Card” for further details.

CONNECTING TO A PICTBRIDGE COMPLIANT PRINTER

If a printer that supports PictBridge is available, images can be printed by connecting the digital still camera directly to the PictBridge-compatible printer without using a computer.

Connecting the camera to the printer

1. Connect one end of the USB cable to your camera.
2. Connect the other end of the USB cable to the USB port on the printer.
3. Turn on your camera.
4. The [USB] screen is displayed. Select [PRINTER] with the ▲/▼ buttons, and press the **SET** button.

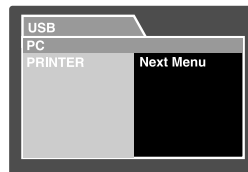

Printing images

When the camera is properly connected to a PictBridge compliant printer, the PictBridge menu is displayed on the monitor.

1. Select the item you want to configure with the ▲/▼ buttons, and press the **SET** button.

- [Images]: Select whether you want to print specific image or all images. You may also select printing number for specific image.
- [Date Print]: According to the printer type, select whether you want to print the image with date imprint or not.
- [Paper Size]: Select the desired paper size according to the printer type.
- [Layout]: Select the desired printing layout according to the printer type.
- [Print]: After all settings are configured, select this item to start printing.

2. If you select [Images] in the previous step, the figure shown on the right hand side will appear. Select [Single] or [All] with the ▲/▼ buttons, and press the **SET** button.

- [Single]: Select to print one specific image.
- [All]: Select to print all images.
- [Exit]: Exit from Images option.

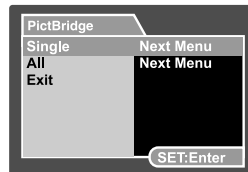
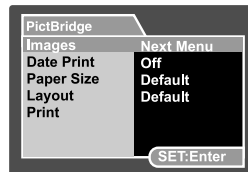

3. If you select [Single] in the previous step, the figure shown on the right hand side will appear.

- Select the image that you want to print with the ◀/▶ buttons.
- Select the [Print Num.] (up to 99) with the ▲/▼ buttons.
- After selecting the desired image and printing number, press the **SET** button to confirm.



4. Select [Exit] with the ▲/▼ buttons, and press the **SET** button.

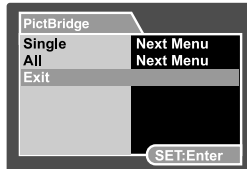

5. Select [Print] with the ▲/▼ buttons, and press the **SET** button to start printing.

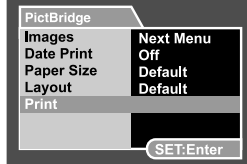

6. The printing starts and the figure shown on the right hand side appears.

- The [Complete] will be displayed temporarily, reminding you that the printing procedure is finished.
- If a print error is detected, the [Print Error] will be displayed.

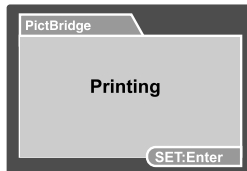

NOTE

- The image printing may be failed if the power to the camera is cut off.
- We recommend that you use the AC power adapter/charger when connecting the camera to the printer.

EDITING SOFTWARE INSTALLATION

Installing Photo Explorer

Ulead® Photo Explorer provides a simple and efficient way to transfer, browse, modify and distribute digital media. Acquire photos, video or sound clips from various digital device types and easily browse or add personal descriptions; make timely modifications; or distribute the media through the medium of your choice: E-mail, Print, Slideshow Presentations. It is an indispensable all-in-one tool for owners of digital cameras, WebCams, DV camcorders, scanners, or anyone who strives to effectively organize a large collection of digital media.

To install Photo Explorer:

1. Insert the CD-ROM that came with the camera into your CD-ROM drive. The welcome screen appears.
2. Click **“INSTALL PHOTO EXPLORER 8.0”**. Follow the on-screen instructions to complete the installation.



NOTE

- For more information about the operation of Photo Explorer application software, refer to its respective help documentation.
- For Windows 2000/XP users, please make sure to install and use the Photo Explorer in “Administrator” mode.
- Photo Explorer is not supported on the Mac. iPhoto or iPhoto2 is recommended.

Installing Photo Express

Ulead® Photo Express is a complete photo project software for digital images. The step-by-step workflow, visual program interface, and in-program help assist users in creating exciting photo projects. Acquire digital photos effortlessly from digital cameras or scanners. Organize them conveniently with the Visual Browse mode. Use hundreds of ready-to-use templates such as albums, cards, posters, slideshows, and more. Edit and enhance images with photo editing tools, photographic filters, and special effects. Embellish projects by adding creative design elements such as frames, callouts, and stamp objects. Share results with family and friends via e-mail and multiple print options.

To install Photo Express:

1. Insert the CD-ROM that came with the camera into your CD-ROM drive. The welcome screen appears.
2. Click **"INSTALL PHOTO EXPRESS 5.0"**. Follow the on-screen instructions to complete the installation.



NOTE

- For more information about the operation of Photo Express application software, refer to its respective help documentation.
- For Windows 2000/XP users, please make sure to install and use the Photo Express in "Administrator" mode.
- Photo Express is not supported on the Mac.

Installing Cool 360

Ulead® COOL 360™ quickly and easily allows photo editing consumers to transform a series of photos into 360° or wide-angle panoramic scenes for an immersive viewing experience. COOL 360's intuitive interface and easy-to-use wizard deliver great-looking panoramas fast while advanced warping, blending and alignment tools ensure excellent results. Share finished panoramas via email, create Web pages or insert them into documents and presentations.

To install Cool 360:

1. Insert the CD-ROM that came with the camera into your CD-ROM drive. The welcome screen appears.
2. Click "**INSTALL Cool 360 SE**". Follow the on-screen instructions to complete the installation.



NOTE

- For more information about the operation of Cool 360 application software, refer to its respective help documentation.
- For Windows 2000/XP users, please make sure to install and use the Cool 360 in "Administrator" mode.
- Cool 360 is not supported on the Mac.

CAMERA SPECIFICATIONS

Item	Description
Image sensor	1/1.7" CCD sensor (10.1 megapixels)
Image resolution	<Still image> 3648 x 2736, 2816 x 2112, 2048 x 1536, 640 x 480 <Video clip> 640 x 480 (25 fps)
LCD monitor	2.5" full color LTPS-TFT LCD (230K pixels)
Recording media	32 MB internal memory (26 MB available for image storage) Supports SD memory card (up to 2 GB) (optional)
File format	JPEG, DCF 1.1, EXIF 2.2, DPOF, Motion JPEG
Lens	3x optical zoom lens Aperture range:2.8(W) – 4.8(T) Focal length:7.5mm – 22.5mm (equivalent to 35mm – 105mm on a 35mm camera)
Shutter speed	1 – 1/1500 sec. (Tv, Manual) 0.5 - 1/1500 sec. (except Tv, Manual)
Digital zoom	10.4x (Capture mode) 2x, 4x & 8x (Playback mode)
Flash effective range	0.5m – 2.7m (Wide/ISO=200)
Terminal	DC IN 5V USB 2.0 (Full speed) / A/V OUT
Power supply	Rechargeable Lithium-ion battery (3.7V) AC power adapter
Dimension	Approx. 91 x 57 x 27mm (without protruding parts)
Weight	Approx. 152g (without battery and SD memory card)

*Design and specifications are subject to change without notice.

TROUBLESHOOTING

Refer to the symptoms and solutions listed below before sending the camera for repairs. If the problem persists, contact your local reseller or service center.

Power Supply

Symptom	Cause	Solution
The power does not come on.	The battery is not inserted.	Insert the battery correctly.
	The battery is exhausted.	Recharge the battery.
	The AC power adapter is not connected correctly.	Reconnect it properly.
The power cuts out during use.	The camera was left unattended and unused, so the auto power off cuts it off.	Turn the power back on.
	The battery is exhausted.	Recharge or use the AC power adapter.
The battery runs out quickly.	It is being used in extreme low temperature.	
	Many shots are being captured in dark places inside, requiring flash.	
	The battery is not fully charged.	Fully charge the battery and discharge it for at least one complete cycle before use to maximize its performance and lifetime.
The battery or camera feels warm.	The battery is not used for an extended period of time after charged.	
	Long period of continuous use of the camera or the flash.	

Shooting

Symptom	Cause	Solution
Even if I press the shutter button, the camera does not shoot.	The battery is running low.	Recharge the battery.
	The power is not on.	Turn the power on.
	The camera is not in shooting mode.	Slide the mode switch to shooting mode.
	The shutter button is not pressed all the way down.	Press the shutter button all the way down.
	The memory card does not have any free capacity.	Insert a new memory card, or delete unwanted files.
	End of memory card life.	Insert a new memory card.
	The flash is charging.	Wait until the status LED off.
	The memory card is unrecognized by the camera.	Format the memory card in this camera before its first use or when it was used other than this camera.
	The auto power off function is activated.	Turn the power on again.
Images do not appear on the LCD monitor.	The memory card is write-protected.	Remove the write-protection.
	The power is not on.	Turn the power on.
Although it is set to auto focus, it does not focus.	LCD monitor is dark.	Adjust the brightness of the LCD monitor in the menu.
	The lens is dirty.	Wipe clean with a soft, dry cloth or lens paper.
The flash does not fire. The flash cannot recharge.	The distance to the subject is smaller than the effective range.	Get your subject within the effective focus range.
	The flash is set to flash off.	Set the flash to something other than flash off mode.
Even though the flash fired, the image is dark.	The distance to the subject is greater than flash effective range.	Get closer to your subject and shoot.
	The flash is too soft.	Adjust the flash offset.
The image is dark.	The image is captured in a dark place while set to flash off.	Set the flash to something other than flash off mode.
	It is under-exposed.	Set the exposure compensation to a larger value.
	The flash is too soft.	Adjust the flash offset.
The image is too bright.	It is over-exposed.	Set the exposure compensation to a smaller value.
	The flash is too strong.	Adjust the flash offset.
The image lacks natural color.	The image was captured in conditions that are hard for auto white balance to adjust to.	Add a white object to the composition.

Playback

Symptom	Cause	Solution
Cannot playback.	It is not set to playback mode.	Slide the mode switch to playback mode.
The contents of memory card cannot be played back.	You played back a memory card that was not formatted by this device.	Insert a memory card that was formatted and stored on by this device.
Files cannot be deleted.	The file is protected.	Cancel protection.
	You played back a memory card that was not formatted by this device.	Insert a memory card that was formatted and stored on by this device.
	The memory card is write-protected.	Remove the write-protection.
Cannot format a memory card.	The memory card is write-protected.	Remove the write-protection.
	End of memory card life.	Insert a new memory card.
The playback image is dark though I used the flash.	The LCD monitor is too dark.	Adjust the brightness of LCD monitor.

Other Problems

Symptom	Cause	Solution
Even when the camera's buttons are pressed, it does not operate.	The battery is running low.	Recharge the battery.
The date and time is wrong.	The correct date and time is not set.	Set the correct date and time.
The date set has disappeared.	The battery is removed with the power still on.	Set the date and time again.

About connecting to your computer/software

Symptom	Cause	Solution
Cannot download images.	The free space on the hard disk in your computer may be insufficient.	Check whether the hard disk has a space for running Windows, and if the drive for loading image files has a capacity at least that of the memory card inserted in the camera.
		Recharge the battery.
	No power supply.	Use AC power adapter. Turn the power on.
Cannot playback video clips on Windows 98 or Windows Me.	DirectX has compatibility issue with Video Driver.	Download and install DirectX 9.0 from Microsoft website.